



A Donaldson Company

A WORLD LEADER IN FUME EXTRACTION TECHNOLOGY

# PrintPRO Universal

Last Updated on 13.04.2021



Fume extraction system for the print and print finishing industries.

BOFA's pioneering extractor, the PrintPRO Universal is designed exclusively for the print and print finishing industries. The PrintPRO Universal's unique features enable it to capture a wide range of solvents generated within these environments, including MEK, ketones and vapours from UV applications.

The PrintPRO Universal is easily adapted to a huge range of environments, including wide format printers, inkjet coding printers (CIJ) (both solvent and UV) and numerous mailroom applications such as UV coating, hot melt glue binding and mailwrap polywrapping.

## Technology



HEPA filter



Advanced carbon filter (ACF) technology



Multi voltage sensing (MVS) unit



ProTECT service plan



SureCHECK quality standard

## Key features of the PrintPRO Universal

VOC gas sensor (Volatile Organic Compound)  
Standard

Extended life carbon for low cost of ownership  
Standard

Low noise level  
Standard

Compact size enables extraction unit to be positioned within the printer footprint  
Standard

Powder coated for durability  
Standard

Filter change indicator  
Standard

Auto sensing voltage (100-240v) for global use  
Standard

Specially treated carbon for safe containment of print fumes  
Standard

Small footprint  
Standard

Castors for portability  
Standard

Digital speed control  
Standard

24V remote stop / start interface via printing machine  
Optional

Contact BOFA at <https://bofainternational.com/en/contact/>  
<https://bofainternational.com/en/portal/datasheets/printpro-universal/>



Approvals: REACH and RoHS. See individual product technical data for specific accreditations

Filter change signal  
Optional



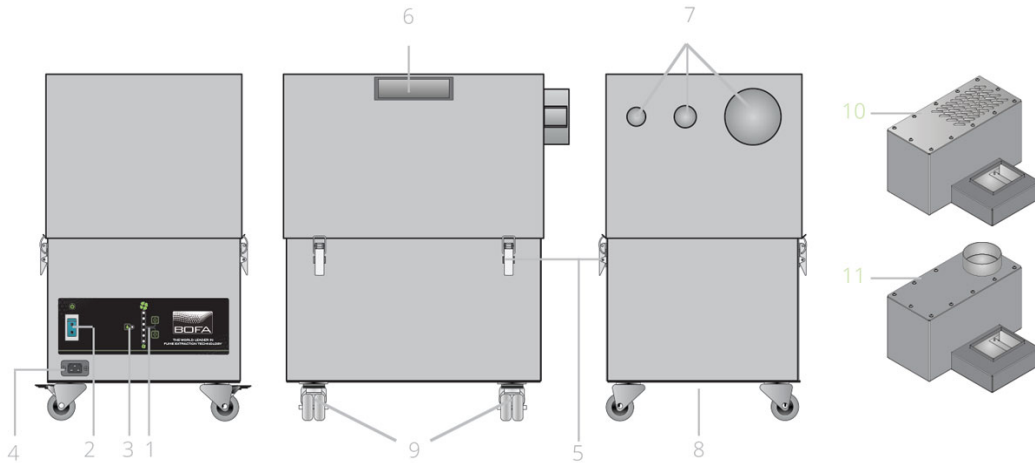

Quiet mode silencer box for office environments, with option to vent outside the building  
Optional

### Technical specification

- 1. Digital speed control
- 2. On / off switch
- 3. Filter condition display
- 4. IEC power cable inlet
- 5. Lid fastening latches
- 6. Handles
- 7. Hose inlet connections - 32mm / 38mm / 100mm
- 8. Exhaust outlet
- 9. Castors
- 10. Optional silencer box with grille
- 11. Optional silencer box with spigot



### Airflow through filters

-  HEPA filter
-  Chemical filter
-  Contaminated air
-  Clean air

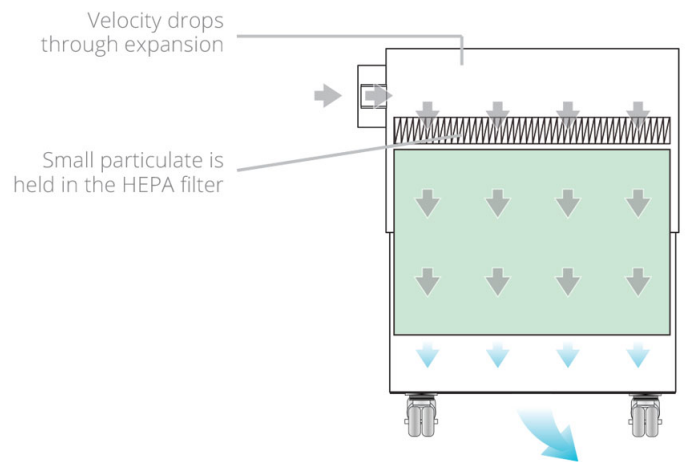

### Technical data

	EU	US
Dimensions (HxWxD)	625 x 385 x 525 mm	24.60 x 15.16 x 20.67
Cabinet construction	Powder coated mild steel	Powder coated mild steel
Airflow / pressure	380m <sup>3</sup> /hr / 96mbar	223cfm / 96mbar
Electrical data	100-240v Single-phase 1~ 50/60Hz Full load current: 12.5 amps/ 1.1kw	100-240v Single-phase 1~ 50/60Hz Full load current: 12.5 amps/ 1.1kw
Noise level	< 68dBA (at typical operating speed)	< 68dBA (at typical operating speed)
Weight	51kgs	113lbs
Approvals	UKCA and CE	cUL, UL*

## HEPA / gas filter specifications

Treated activated carbon	20kgs (44 lbs)
Filter media	Borosilicate
Filter housing	Zintec mild steel
Surface media area	3.5m <sup>2</sup> approx (37.66 ft <sup>2</sup> )

## Unit part numbers

Model	Part no.
PrintPRO Universal Powder coated	L2044A

## Options

24V stop / start	Filter change / system failure signal	Silencer box with spigot	Silencer box with air return grille
A2001	A2002	A1060052	A1060187

## Replacement filter

Combined HEPA / gas filter	A1030157
----------------------------	----------

\* Tested to UL and cUL standards, but testing may be provided by alternate nationally recognised test laboratories. Certain product configurations may affect the UL certification. Please speak to your sales representative.

*Datasheet correct at time of publishing.*

*Where applicable, the carbon used in BOFA units is capable of removing a wide range of VOCs, however it is the responsibility of the user to ensure the carbon is suitable for their application. For specific applications, please contact us for details.*

**Important Notice:** *Many factors beyond the control of BOFA can affect the use and performance of BOFA products in a particular application, including the conditions under which the product is used. Since these factors are uniquely within the user's knowledge and control, it is essential the user evaluate the products to determine whether the product is fit for the particular purpose and suitable for the user's application. All products, product specifications, availability and data are subject to change without notice, and may vary by region or country.*

*Think before you print! Please consider the environment before printing this document.*

